

W429 BP630

11/7/07



# **HARE & FORBES**

## **MACHINERYHOUSE**

Established 1930

Distributors of New & Used Workshop Equipment

# **WOOD CUTTING BAND SAW**

**MODEL: BP-630**

**OPERATION MANUAL AND PARTS LIST**

# WOOD CUTTING BAND SAW OWNERS MANUAL

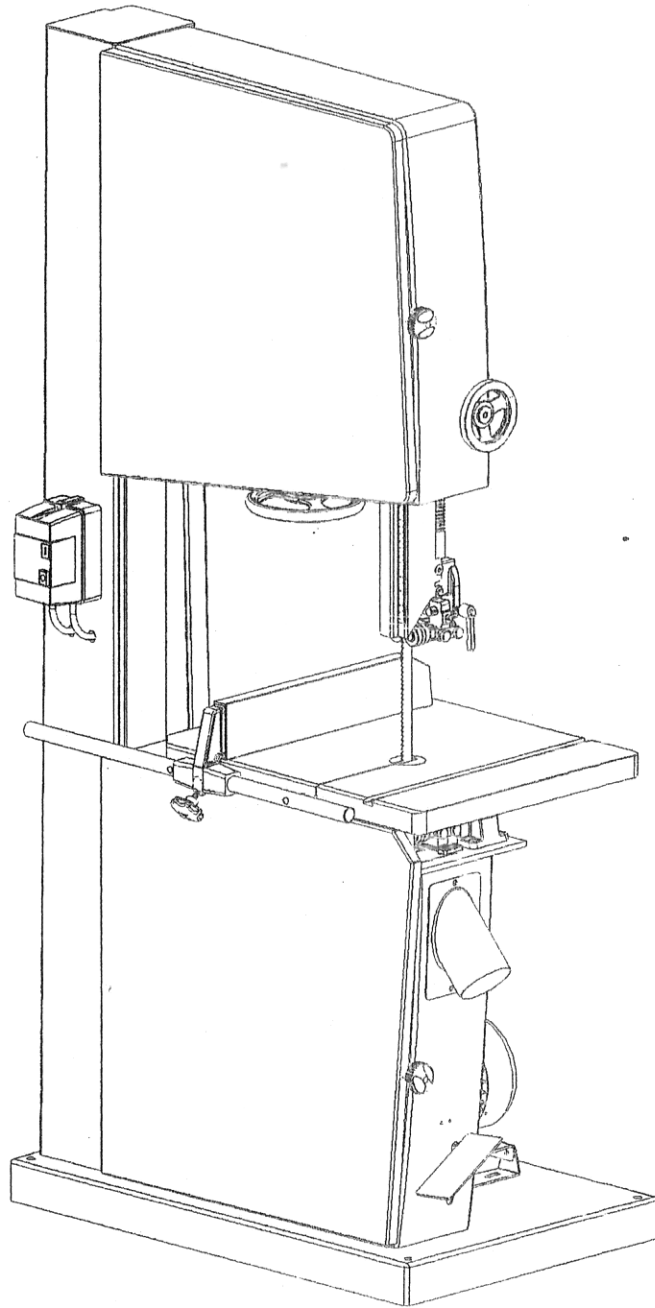

ATTENTION : Before using be sure to read this manual .

---

---

1. FOR YOUR OWN SAFETY, READ INSTRUCTION MANUAL BEFORE OPERATION THE TOOL.
2. KEEP GUARDS IN PLACE AND IN WORKING ORDER.
3. GROUND ALL TOOLS.
4. REMOVE ADJUSTING KEYS AND WRENCHES.
5. KEEP WORK AREA CLEAN.
6. DON'T USE IN DANGEROUS ENVIRONMENT.
7. KEEP CHILDREN AND VISITORS AWAY.
8. MAKE WORKSHOP CHILDPROOF.
9. DON'T FORCE TOOL.
10. USE RIGHT TOOL.
11. WEAR PROPER APPAREL.
12. ALWAYS WEAR EYE PROTECTION.
13. SECURE WORK.

Use clamp or a vise to hold work when practical. It's safer than using your hand and frees both hands to operate tool.

14. DON'T OVERREACH.

Keep proper footing and balance at all times.

15. MAINTAIN TOOLS IN TOP CONDITION.
16. DISCONNECT TOOLS.

Before servicing and when changing accessories such as blades, bits, cutters, etc.

17. USE RECOMMENDED ACCESSORIES.
18. AVOID ACCIDENTAL STARTING.

Make sure switch is in "OFF" position before plugging in power cord.

19. NEVER STAND ON TOOL.
20. CHECK DAMAGED PARTS.
21. DIRECTION OF FEED.

Feed work into a blade or cutter against the direction of rotation of the blade or cutter against the direction of rotation of the blade or cutter only.

22. NEVER LEAVE TOOL RUNNING UNATTENDED. TURN POWER OFF.

Don't leave tool until it comes to a complete stop.

23. DRUGS, ALCOHOL, MEDICATION.

Do not operate tool while under the influence of drug, alcohol or any medication.

24. MAKE SURE TOOL IS DISCONNECTED FROM POWER SUPPLY.

While motor is being mounted, connected or reconnected.

---

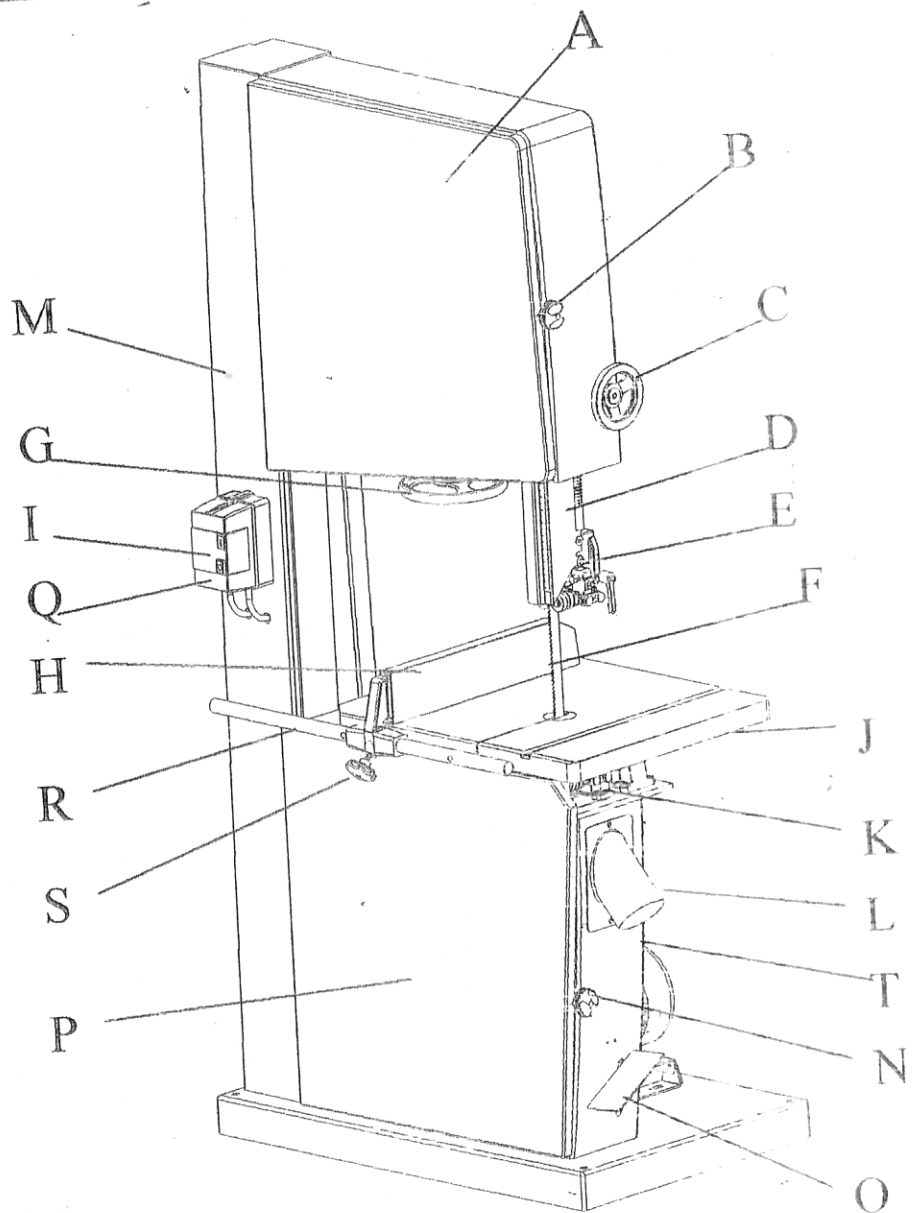

Fig . 1

- A. Upper wheel guard
- C. Adjustment blade guard hand wheel
- E. Blade guide support (Upper)
- G. Adjust wheel
- I. Stop switch
- K. Blade guide support (Lower)
- M. Body
- O. Brake pedal
- Q. Switch
- S. Fence knob

- B. Cross knob
- D. Blade guard
- F. Saw blade
- H. Fence
- J. Working table
- L. Dust chute
- N. Cross knob
- P. Lower wheel guard
- R. Fence guide pipe
- T. Belt Cover

The band saw it is complete with two wheels are particularly suitable to cut wood, plastics, alloy, and can carry out longitudinal, transversal, oblique cuts and all outlining operations.

The working table has grounded cast iron. It can be tilted up to 45° and includes a fence for straight cuts adjustable both on the right and on the left of the blade.

(When you want turn the table to any angle before, Fig 2 Handle turn out, then turn lock)

Fig . 2

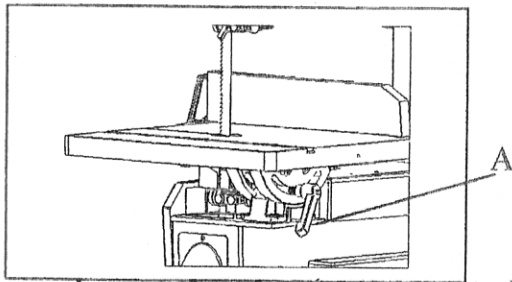
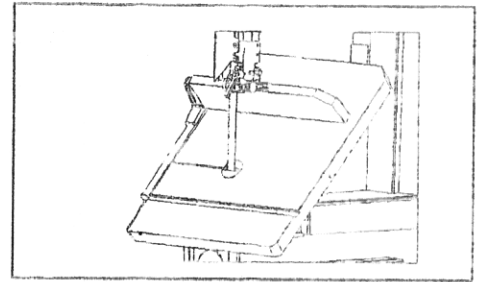

Fig . 3



The two cast iron wheels (new style) are perfectly balanced and rubber coated. (Fig 4)

Fig. 1(G) Adjust wheel for the upper wheel is adjustable in its height in order to enable to assemble and disassemble the blade. (Fig 4)

Want check blade in the center, you can find the machine back, you can see have two knob screw and four set screw, knob screw its control wheel in-side or outside, and set screw its control wheel on the right or left. (Fig 5)

Fig 4

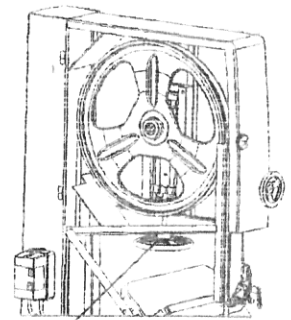

Adjust Wheel

Fig 5

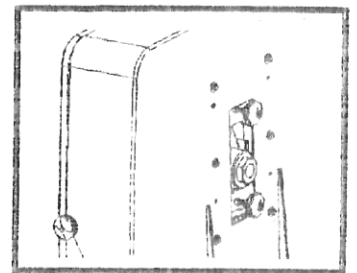

The lower wheel is provided with a little brush, which maintains it always cleaned from sawdust. (Fig. 6)

Fig 6

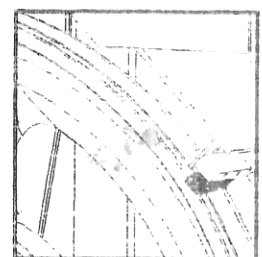

The guides of blade are easily adjustable (Fig7)

The upper guide (lower guide) can be vertically removed. ( Fig 8 )

When remove must turn out A(Fig 9)

It is also provided with the appropriate safety guide.

Fig 7

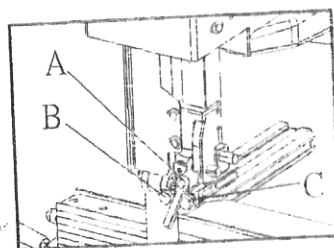

Fig 8

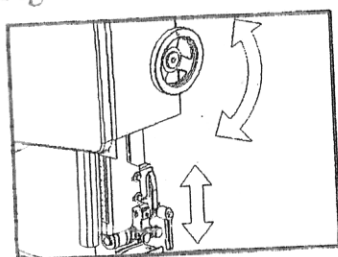

Fig 9

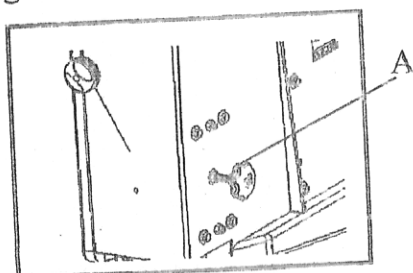
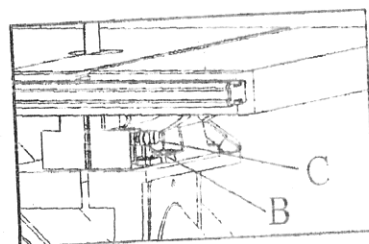
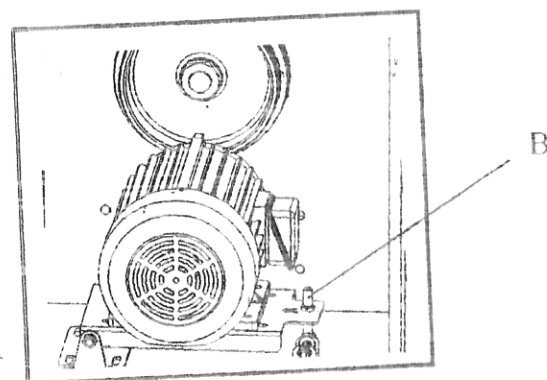

Fig 10



Adjust belt it's very easily, only turn two hex nut(B)up or down.(Fig 11)

Fig 11



The band saws are provided with all safety guards according to the safety regulation. ( Fig 12 )

Fig 12

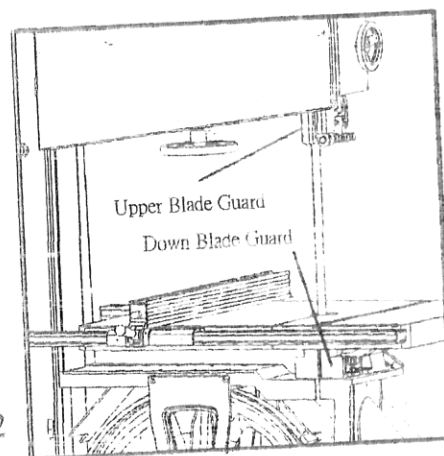

The machine base have four holes (20"-783mm\*506mm(24"-920mm\*558mm)),its can bracket on the land for the working.

- Before connecting the machine to the network, be sure that tension corresponds to the one indicated on the motor.
- The ball bearings are self-lubricated and do not need to be oiled any longer.
- The rubber coating on wheels has to be kept perfectly cleaned in order to avoid unbalances and vibrations during working operations.
- Be careful that blade works with its teeth on the rubber edges in order to avoid scratches and breakings on it.
- When the cutting operation is terminated, always loosen the blade otherwise it could get broken.
- A correct use and maintenance of the machine will prevent it from any damage.

(Fig 13) The adjust wheel allows the tensioning of the blade and its assembling and disassembling.

Fig 13

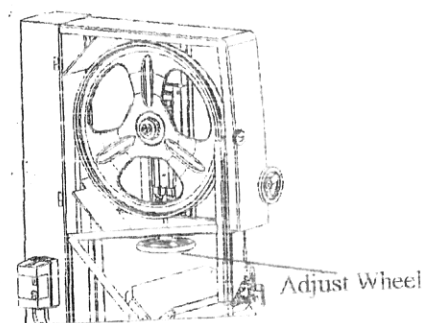

After machine have knob screw can adjust blade on the order.(Fig 14)

Fig 14

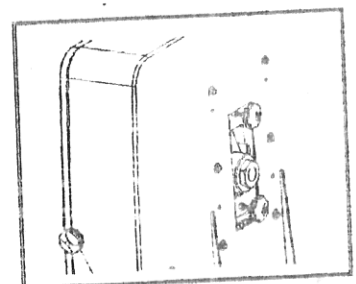

The blade guide support has to rotate only when the blade is cutting and should have a distance of 1-2 mm from the blade back when not operating. (Fig 15)

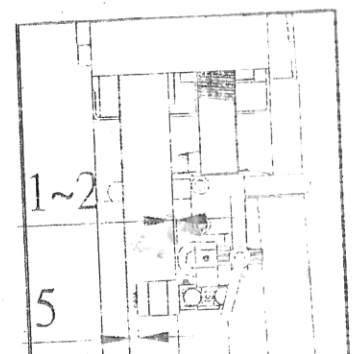

Fig 15

---

In order to adjust the guide support its necessary to intervene on the locking screw by means of the spanner supplied as standard.(Fig 15)

The blade guide supports have to be adjusted by means of the relative locking screw and have to maintain a distance of 0.5 mm from the blade.(Fig 15)

The blade guide supports should never touch the blade teeth.

The same written above applies for the adjustment of the lower blade guide located under the worktable.(Fig 16)

The band saw it is provided with an upper blade guide mounting special hardened and rotating discs which allow the lateral centering.

The lateral discs have to be adjusted by means of the apposite knob and locked at the correct position of 0.5mm from the blade back side.

The upper blade guide unit can be adjusted in its height by means of the knob (Fig 17)(Fig 18). It has to be set according to the thickness of the piece being cut and maintained at a distance of 5mm from it.

A special device on the blade guide avoids that it goes down when loosening the knob screw, than turn the hand wheel (Fig 17)(Fig 18)

Fig 16

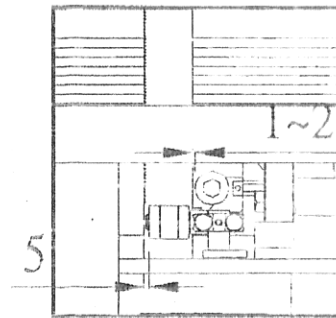

Fig 17

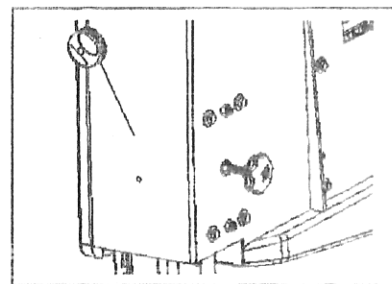
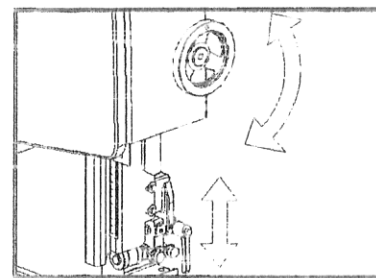
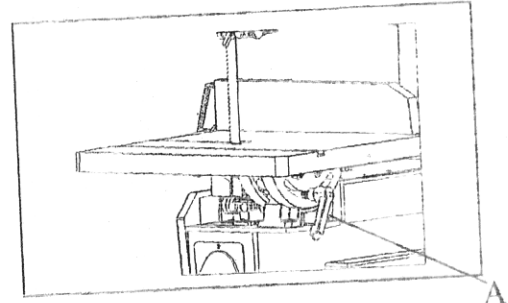
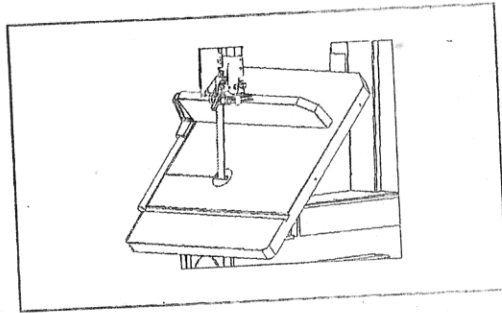

Fig 18





Loosen the screw(Fig 19 ,A) nut and lock them when the table is at desired position.



Take off all rubber from the wheel with acetone. Assemble the new rubber coating and glue it to the wheel by means of basic or similar material and turn the glued rubber in order to level the thickness and render it slightly convex.

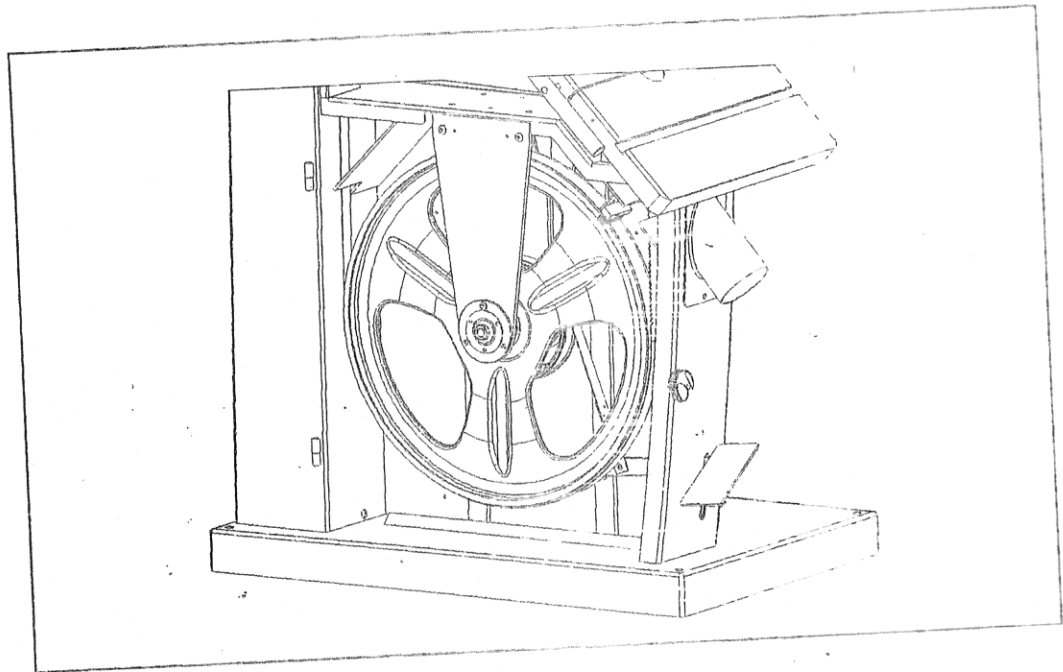

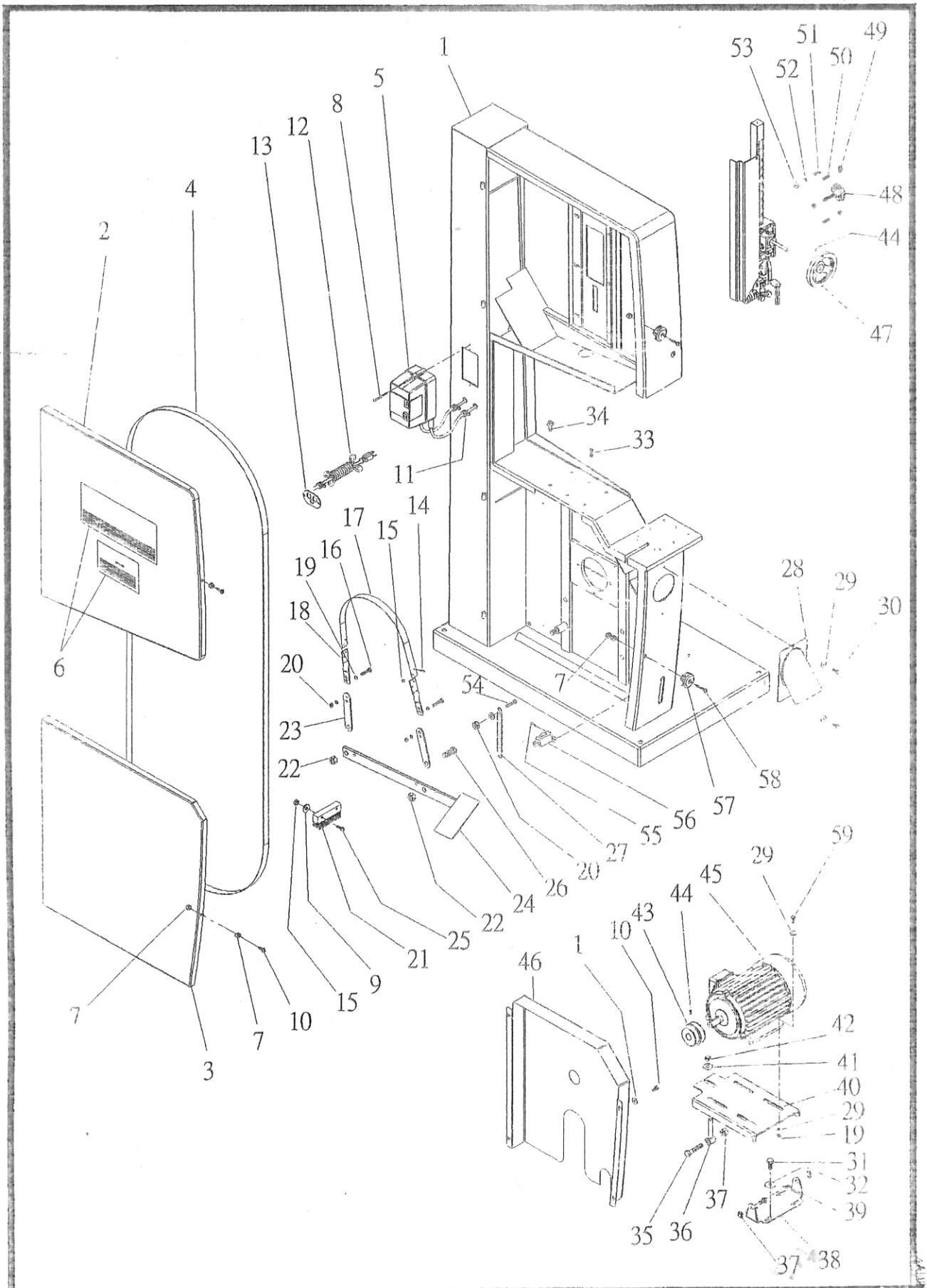

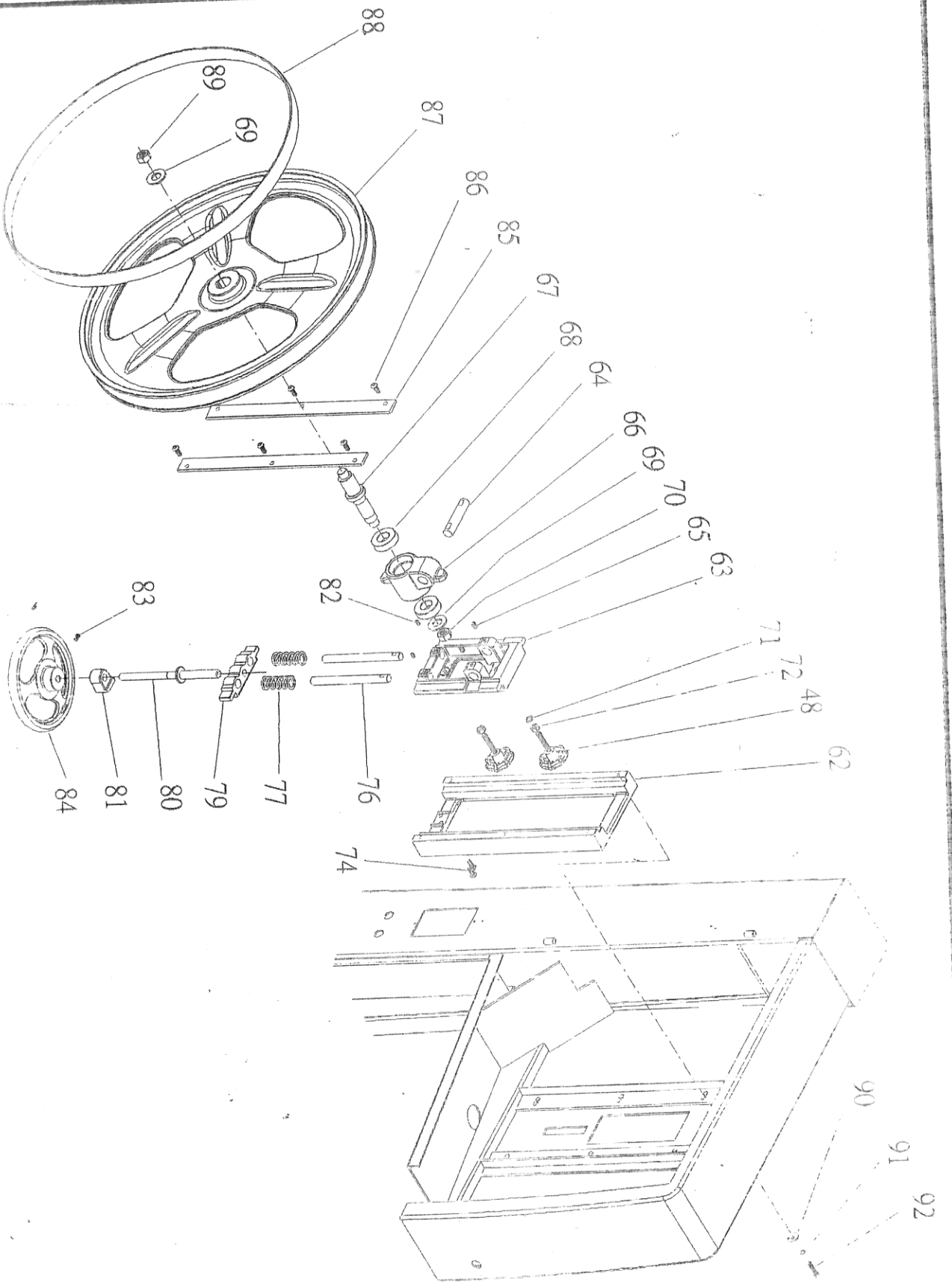

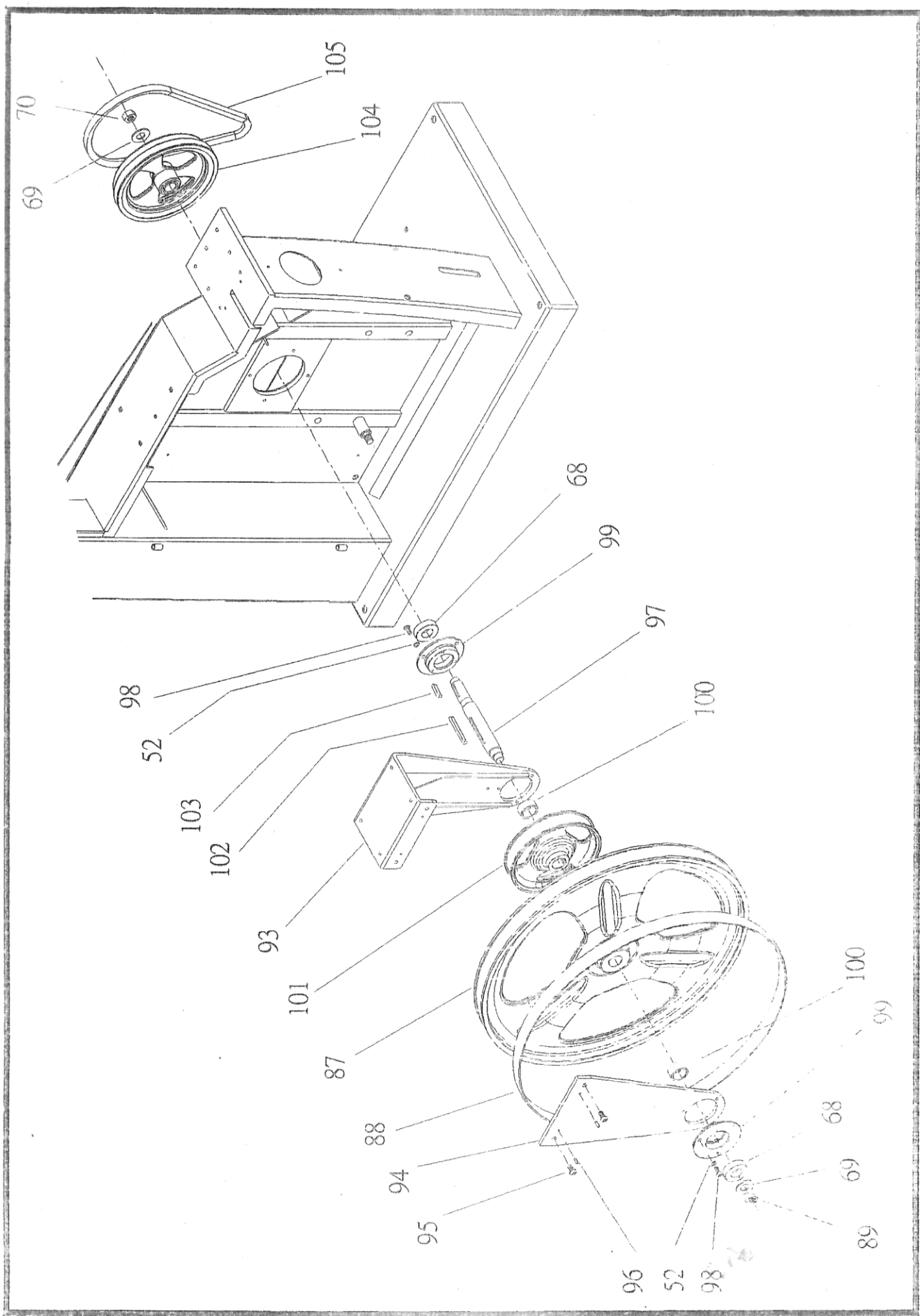

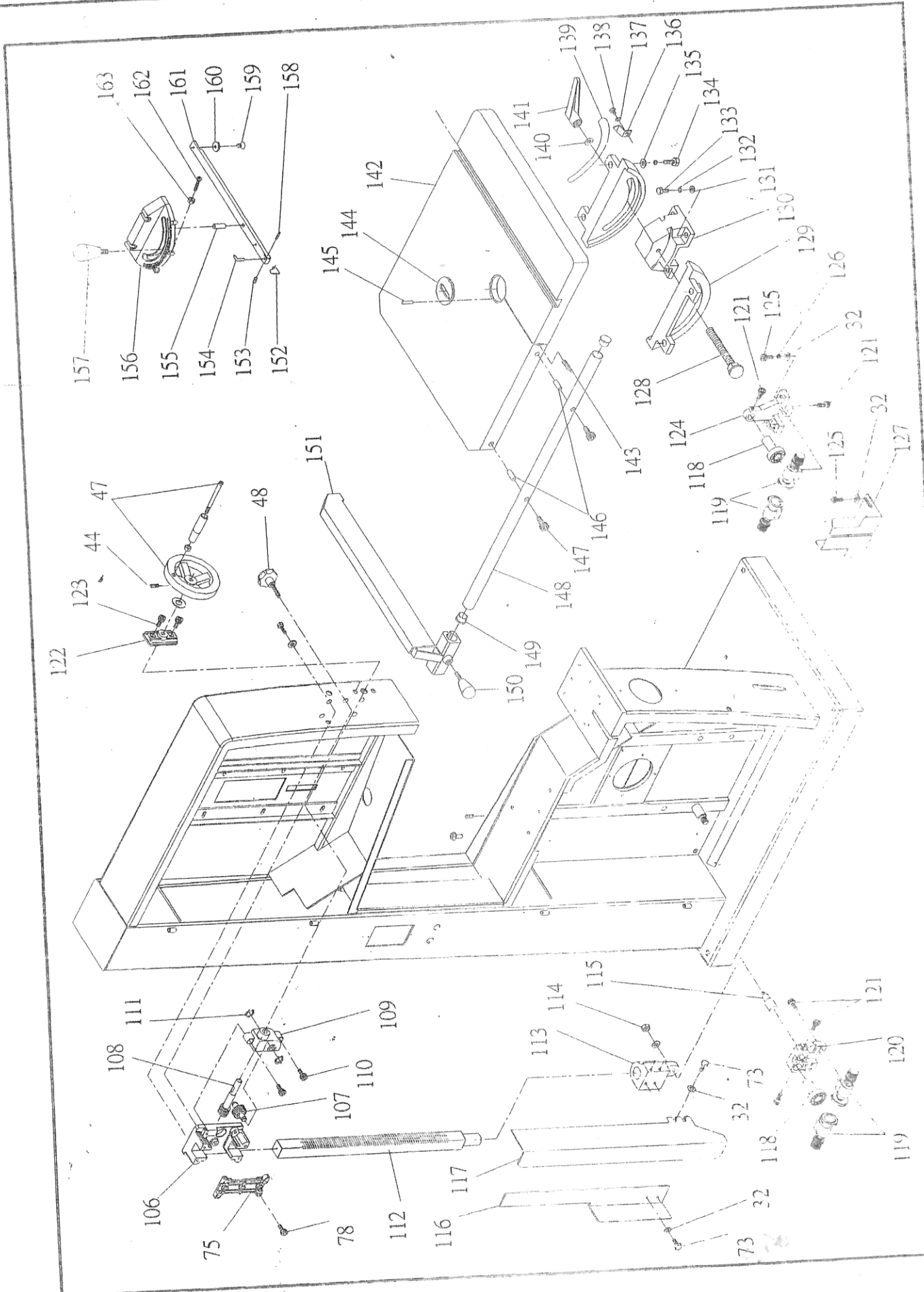

Index No.	Part No.	Description	Size	Q'ty
1		Machine Body		1
2		Upper Front Door		1
3		Lower Front Door		1
4		Replacement Blade		1
5		Switch ON/OFF	20D	1
6		Name Plate		1
7		Hex Nut	1/4"	2
8		Pan Screw	3/16"-24UNC x 1-1/2"	2
9		Flat Washer	3/16"	2
10		Pan Screw	1/4"x3/4"	2
11		Strain Relief		4
12		Power Cord & Motor Cord		1
13		Power Cord Locking Flat Plate		1
14		Pan Screw	3/16"x1/2"	4
15		Hex Nut	3/16"	4
16		Hex Screw	5/16"-18UNC x 1" L	2
17		Brake Belt		1
18		Brake Belt Locking Plate		2
19		Flat Washer	5/16"	4
20		Hex Nut	5/16"	4
21		Brush		1
22		Nylon Locking Nut	5/8"	2
23		Short Connect Plate		2
24		Brake Pedal		1
25		Pan Screw	3/16"x1-1/2"	2
26		Hex Screw	5/8"-11UNC x 1.5" L	1
27		Spring		1
28		Dust Chute		1
29		Flat Washer	5/16"	2
30		Hex Screw	5/16"-18UNC x 1-1/2"	2
31		Hex Screw	5/16"-18UNC x 1-1/2" L	4
32		Flat Washer	5/16"	10
33		Set Screw	3/8"-16UNC x 3/4" L	2
34		Cup Screw	3/8"-16UNC x 1" L	4
35		Hex Screw	3/8"-16UNC x 2.5" L	1
36		Adjustment Bolt		1
37		Nylon Locking Nut	3/8"	1
38		Motor Support Plate		1
39		Hex Screw	1/2"-13UNC x 1" L	2
40		Motor Locking Plate		1
41		Flat Washer	1/2"	2
42		Hex Nut	1/2"	2
43		Motor Pulley		1
44		Set Screw	5/16"-18UNC x 5/8" L	1
45		Motor		1
46		Pulley Safe Cover		1

48	Locking Knob		1
49	Hex Nut	3/8"	5
50	Set Screw	3/8"-16UNC x 1" L	5
51	Hex Screw	3/8"-16UNC x 1" L	4
52	Spring Washer	3/8"	4
53	Flat Washer	3/8"	4
54	Hex Screw	5/16"x2"L	1
55	Pan Screw	3/16"x1"	2
56	Brake Switch		1
57	Lock Knob		2
58	Pan Screw	1/4"x5/8"	2
59	Hex Screw	5/16"x1-1/2"	4
60			
61			
62	Upper Wheel Bracket Base		1
63	Upper Wheel Adjustment Bracket Base		1
64	Transverse Shaft		1
65	Set Screw	5/16"-18UNC x 1/2" L	2
66	Upper Wheel Shaft Locking Base		1
67	Upper Wheel Shaft		1
68	Ball Bearing	6205ZZ	4
69	Flat Washer	3/4"	4
70	Locking Nut	3/4"-16UNF Right	2
71	Spring Washer	3/8"	2
72	Hex Nut	3/8"	2
73	Hex Screw	1/4"x5/8"	4
74	Cap Screw	5/16"x3/4"	2
75	Cover		1
76	Spring Spindle		2
77	Spring		2
78	Cap Screw	5/16"x3/4"	4
79	Elevator Bracket		1
80	Adjustment Screw		1
81	Locking Base		1
82	Set Screw	1/4"x3/8"	2
83	Set Screw	5/16"x5/8"	2
84	8" Handwheel		1
85	Locking Press Plate		2
86	Cap Screw	5/16"-18UNC x 3/4" L	8
87	Blade Wheel		2
88	Rubber Tire		2
89	Locking Nut	3/4"-16UNF Left	2
90	Flat Washer	5/16"	6
91	Spring Washer	5/16"	6
92	Hex Screw	5/16"-18UNC x 1-1/2"	8
93	Lower Blade Wheel Bracket Base		1

96	Spring Pen	5x15	2
97	Lower Blade Wheel Main Shaft		1
98	Pan Head Cap Screw	5/16"-18UNC x 3/4" L	6
99	Bearing Base		2
100	Bushing		2
101	Brake Wheel		1
102	Key	7x7x80	1
103	Key	7x7x30	1
104	Main Shaft Pulley		1
105	V-Belt		1
106	Guide Bar Case Bracket		1
107	Gear & Shaft		1
108	Worm		1
109	Gear Base		1
110	Cap Screw	5/16"-18UNC x 3/4" L	4
111	C-Ring	S-12	2
112	Guide Bar		1
113	Guide Bar Bracket		1
114	Hex Nut	1/2"	1
115	Locking Bar		1
116	Blade Inter Guard		1
117	Blade Guard		1
118	Blade Support Shaft		2
119	Guide Wheel		4
120	Upper Guide Bracket		1
121	Cap Screw	1/4"x5/8"	11
122	Bracket Base		1
123	Cap Screw	5/16"-18UNC x 3/4" L	2
124	Lower Guide Bracket		1
125	Hex Screw	1/4"x1-1/4"	2
126	Spring Washer	1/4"	2
127	Lower Blade Guard		1
128	Hex Screw	5/8"x6"	1
129	Trunnion		2
130	Table Gage Bracket		1
131	Flat Washer	3/8"	4
132	Spring Washer	3/8"	4
133	Hex Screw	3/8"x1-1/4"	4
134	Hex Screw	3/8"x1-1/2"	4
135	Flat Washer	3/8"	4
136	Pointer		1
137	Gear Washer	M5	1
138	Pan Screw	M5x12	1
139	Angle Scale		1
140	Flat Washer	5/8"	1
141	Locking Handle		1
142	Working Table		1



144	Table Insert		1
145	Spring Pin	3x10	1
146	Bushing		2
147	Cap Screw	5/16"x2-1/2"	2
148	Fence Rail		1
149	Rail Cover		2
150	Fence Locking Knob		1
151	Fence		1
152	Locking Plate		1
153	Set Screw		1
154	Pointer		1
155	Pin		1
156	Miter Gauge		1
157	Miter Gauge Locking Knob		1
158	Pin		1
159	Screw		1
160	Flat Disc		1
161	Miter Gauge Bar		1
162	Pan Screw	3/16"x1"	3
163	Hex Nut	3/16"	3
164	Manual		1